

BULK MATERIAL GRAB

PALFINGER



OUTSTANDING FILLING CHARACTERISTICS





Special designed for collecting material on any kind of surface. Owing to the special shell form and the wide distance of the shell pivots an optimum filling characteristic is achieved. The vertical cutting edges in the open position favour the dig-in function into the bank/bulk material. Many advantages bring the combination of balancing mechanism and cylinder protection: Guaranteed balanced running of the grab shells, longer life time of piston rod and seals as well as a considerable weight reduction. Low overall height through horizontally fitted hydraulic cylinders. High closing force. Bolt type excavator teeth are available as accessory. Operating pressure: 260 bar (3771 psi). All attachments have integrated overload valves. Also available as complete package ready to mount on the crane. Suspensions to other crane brands available on request!



Model	Capacity	Width (A)	Weight	Excavator teeth (optional)
PZG300S	300l (0.40 c.y.)	500 mm (19.68")	420 kg (926 lbs)	5
PZG400S	400l (0.52 c.y.)	800 mm (31.50")	450 kg (992 lbs)	9
PZG500S	500l (0.65 c.y.)	1000 mm (39.37")	465 kg (1025 lbs)	9
PZG650S	650l (0.85 c.y.)	1200 mm (47.24")	480 kg (1058 lbs)	9
PZG1000S*	1000l (1.30 c.y.)	1200 mm (47.24")	690 kg (1521 lbs)	9

* Measurements for PZG1000S on request.

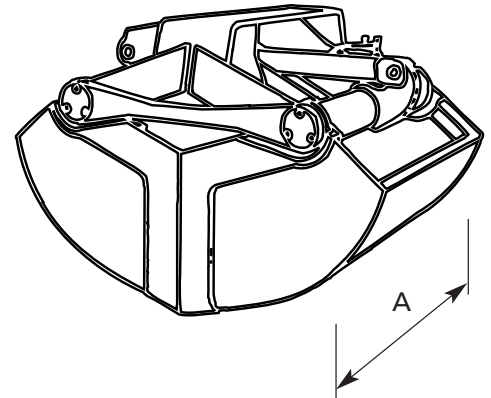

Model	Capacity	Width (A)	Weight	Excavator teeth (optional)
PZG300S-1	300l (0.40 c.y.)	640 mm (25.19")	335 kg (738 lbs)	5
PZG400S-1	400l (0.52 c.y.)	800 mm (31.50")	345 kg (760 lbs)	9
PZG500S-1	500l (0.65 c.y.)	1000 mm (39.37")	360 kg (793 lbs)	9

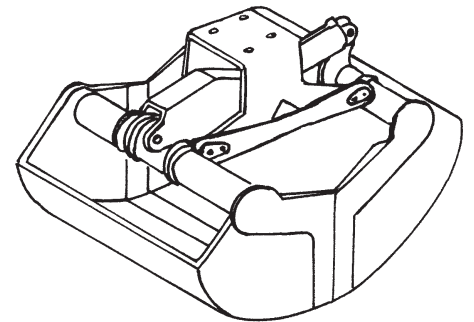

PZG-S

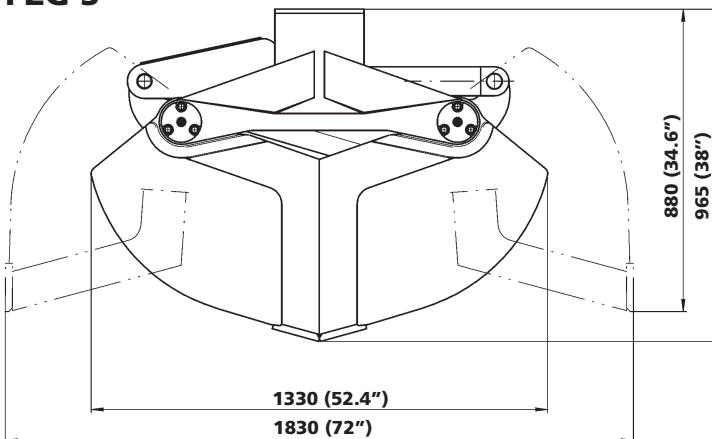

PZG-S-1

